

UNCONTROLLED DOCUMENT

PART NUMBER
SSB-COB9719GW-A

REV.

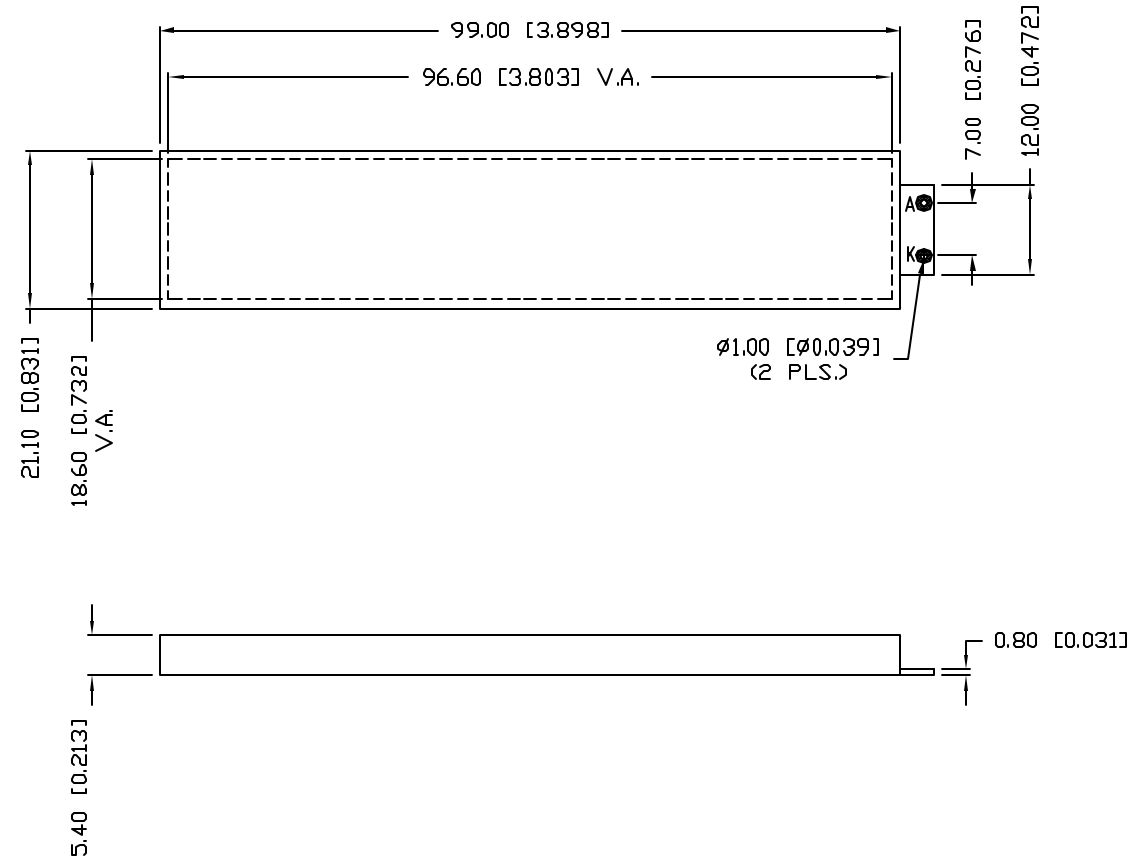

ELECTRO-OPTICAL CHARACTERISTICS $T_A=25^\circ\text{C}$ PER MODULE $I_f=190\text{mA}$

PARAMETER	MIN	TYP	MAX	UNITS	TEST COND
PEAK WAVELENGTH		565		nm	
FORWARD VOLTAGE		4.2	4.5	V_f	
REVERSE VOLTAGE	8			V_r	$I_f=1.9\text{mA}$
LUMINOUS INTENSITY		235		cd/m^2	$I_f=190\text{mA}$
EMITTED COLOR:	GREEN				
REFLECTOR FINISH:	WHITE				

LIMITS OF SAFE OPERATION AT 25°C PER MODULE

PARAMETER	MAX	UNITS
STEADY CURRENT	310	mA
POWER DISSIPATION	1.4	W
DERATE FROM 25°C , PER DIE	-1.2	$\text{mW}/^\circ\text{C}$
OPERATING, STORAGE TEMP.	-40 TO +85	$^\circ\text{C}$
SOLDERING TEMP.	+260	$^\circ\text{C}$
2.0mm FROM BODY		3 SEC. MAX

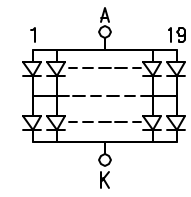

2 CHIPS IN SERIES
19 PARALLEL BRANCHES

UNCONTROLLED DOCUMENT

*UNLESS OTHERWISE SPECIFIED TOLERANCES PER DECIMAL PRECISION ARE: X=±1 (±0.039), XX=±0.5 (±0.020), XXX=±0.25 (±0.010), XXXX=±0.127 (±0.005). LEAD SIZE=±0.05 (±0.002), LEAD LENGTH=±0.75 (±0.030). MIN= +DECIMAL PRECISION -0.00 MAX.= +0.00 -DECIMAL PRECISION

REV. PART NUMBER
SSB-COB9719GW-A

CONFIDENTIAL INFORMATION
THE INFORMATION CONTAINED IN THIS DOCUMENT IS THE PROPERTY OF LUMEX INC. EXCEPT AS SPECIFICALLY AUTHORIZED IN WRITING BY LUMEX INC., THE HOLDER OF THIS DOCUMENT SHALL KEEP ALL INFORMATION CONTAINED HEREIN CONFIDENTIAL AND SHALL PROTECT SAME IN WHOLE OR IN PART FROM DISCLOSURE AND DISSEMINATION TO ALL THIRD PARTIES.

RELIABILITY NOTE
OUR MANY YEARS OF EXPERIENCE DATA ACCUMULATION INDICATE THAT SOLDER HEAT IS A MAJOR CAUSE OF EARLY AND FUTURE FAILURE. PLEASE PAY ATTENTION TO YOUR SOLDERING PROCESS.

LUMEX
290 E. HELEN ROAD
PALATINE, IL 60067-6976
PHONE: +1.847.359.2790
US WEB: www.lumex.com
TW WEB: www.lumex.com.tw

97mm x 19mm VIEW AREA, CHIP ON BOARD LED BACKLIGHT,
565nm GREEN, 38 CHIPS, 4.2V @ 190mA.

DRAWN BY: JO
CHECKED BY:
APPROVED BY: DATE: 9.28.04
PAGE: 1 OF 1
SCALE: N/A